

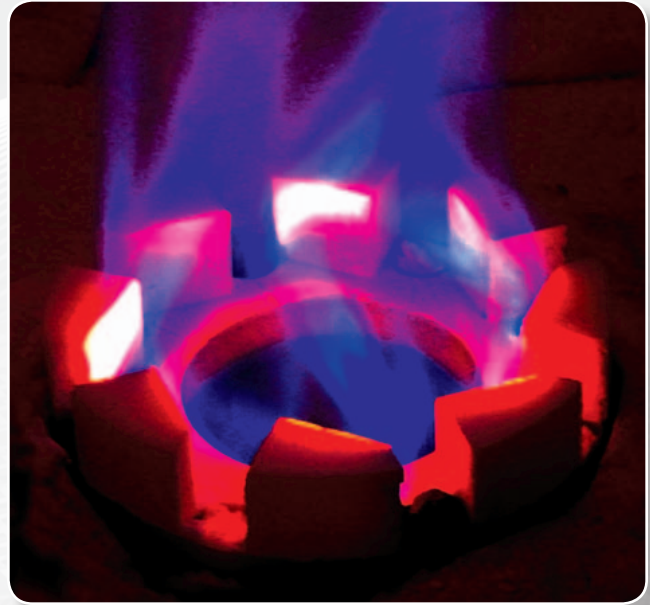

MIN-EMISSIONS ROUND FLAME GAS BURNER

COMBUSTION AND ENVIRONMENTAL SOLUTIONS.
PURE AND SIMPLE.®

GLSF Series



GLSF Min-Emissions Round Flame Gas Burners

DESCRIPTION

The ZEECO® GLSF Min-Emissions burner is an ultra-low emissions round flame burner. The design allows for a compact flame shape which is basically the width of the burner tile making Zeeco's burners a great choice for applications that require the burners to be mounted close together or far apart while still achieving ultra-low NO_x.

WHY CHOOSE ZEECO?

Zeeco leads today's global market in the design of combustion equipment. Our engineers have the experience, knowledge, and tools to properly design your burner equipment. ZEECO burners have been operating around the globe for over 30 years. Our philosophy of providing customers with superior quality, on-time shipments, and competitive pricing is the cornerstone of our success. Let us put our experience to work for you. Call or email us today to learn more about the full line of ZEECO burner products and replacement components for your new or existing burner system.



BURNERS



FLARES



INCINERATORS



PARTS & SERVICE

COMBUSTION AND ENVIRONMENTAL SOLUTIONS. PURE AND SIMPLE.®

Min-Emissions Round Flame Gas Burner

DESIGN FEATURES

- Stable flame over a wide range of conditions
- High turndown of 5:1 or greater for most cases
- No stabilization metal used in the burner throat
- Low maintenance cost since tip mass is small and exposed into firebox less than 1" (25 mm)
- Compact design makes this burner a great choice for retrofit applications
- Compact flame shape
- Reasonable cost and great value
- Combustion air dampers are controlled by gears for precise control
- Bearings are used for the combustion air damper shafts for smooth, precise operation
- Plenum mounted or individual wind-box configurations
- 310 Stainless Steel (Type HK) gas tips

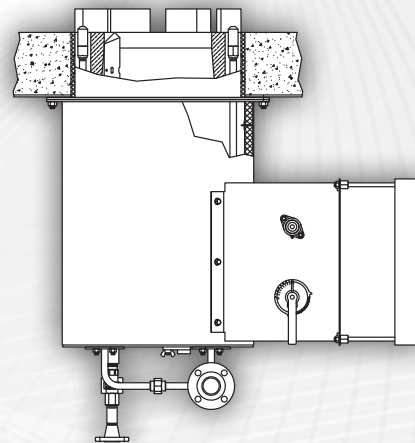

GLSF Min-Emission Burner

DESIGN INFORMATION

Burner Model: GLSF Min-Emissions Burner
 Fuels: Gas Only
 Description: Round Flame Ultra-Low Emissions
 NO_x Reduction Method: Internal Flue Gas Recirculation by Free-Jet Mixing
 Predicted NO_x Emissions Range (Natural Draft): 30 ppmv to 45 ppmv
 Predicted NO_x Emissions Range (600°F/316°C Air Preheat): 50 ppmv to 80 ppmv
 Combustion Air Induction: Natural, Forced, Induced & Balanced Draft
 Mounting Options: Up-fired and Side-fired
 Natural Draft Heat Release Range: 1 MM to 20 MM Btu/hr [0.293 to 5.860 MW]
 Forced Draft Heat Release Range: 1 MM to 50 MM Btu/hr [0.293 to 14.650 MW]
 Turndown: 5:1
 Typical Excess Air Range: 10% to 25%

CERTIFICATIONS APPLY TO ZEECO HEADQUARTERS ONLY.



CERTIFIED NBBI



CERTIFIED ASME



CERTIFIED ASME



REGISTERED ISO 9001: 2008

Zeeco Corporate Headquarters
 22151 East 91st Street
 Broken Arrow, Oklahoma 74014 USA
 Phone: +1.918.258.8551
 Fax: +1.918.251.5519
 E-mail: sales@zeeco.com



zeeco.com

ZEECO® is a registered trademark of Zeeco, Inc. in the U.S.
 • ZEECO office, affiliate, sales, representative, or third party representative/licensee offices.
 © COPYRIGHT 2011 - ZEECO, INC. ALL RIGHTS RESERVED